

COVER PAGE OF THE ANNUAL ARTICLE 7 REPORT

NAME OF STATE [PARTY]: THE REPUBLIC OF CROATIA

REPORTING PERIOD: 01/01/2024 to 31/12/2024
 (dd/mm/yyyy) (dd/mm/yyyy)

<p>Form A: National implementation measures:</p> <table border="1"> <tr><td><input checked="" type="checkbox"/></td><td>changed (last reporting: 2024)</td></tr> <tr><td><input type="checkbox"/></td><td>unchanged</td></tr> <tr><td><input type="checkbox"/></td><td>non applicable</td></tr> </table>	<input checked="" type="checkbox"/>	changed (last reporting: 2024)	<input type="checkbox"/>	unchanged	<input type="checkbox"/>	non applicable	<p>Form F: Program of APM destruction:</p> <table border="1"> <tr><td><input type="checkbox"/></td><td>changed</td></tr> <tr><td><input checked="" type="checkbox"/></td><td>unchanged (last reporting: 2009)</td></tr> <tr><td><input type="checkbox"/></td><td>non applicable</td></tr> </table>	<input type="checkbox"/>	changed	<input checked="" type="checkbox"/>	unchanged (last reporting: 2009)	<input type="checkbox"/>	non applicable
<input checked="" type="checkbox"/>	changed (last reporting: 2024)												
<input type="checkbox"/>	unchanged												
<input type="checkbox"/>	non applicable												
<input type="checkbox"/>	changed												
<input checked="" type="checkbox"/>	unchanged (last reporting: 2009)												
<input type="checkbox"/>	non applicable												
<p>Form B: Stockpiled anti-personnel mines:</p> <table border="1"> <tr><td><input type="checkbox"/></td><td>changed</td></tr> <tr><td><input checked="" type="checkbox"/></td><td>unchanged (last reporting: 2003)</td></tr> <tr><td><input type="checkbox"/></td><td>non applicable</td></tr> </table>	<input type="checkbox"/>	changed	<input checked="" type="checkbox"/>	unchanged (last reporting: 2003)	<input type="checkbox"/>	non applicable	<p>Form G: APM destroyed:</p> <table border="1"> <tr><td><input checked="" type="checkbox"/></td><td>changed (last reporting: 2024)</td></tr> <tr><td><input type="checkbox"/></td><td>unchanged</td></tr> <tr><td><input type="checkbox"/></td><td>non applicable</td></tr> </table>	<input checked="" type="checkbox"/>	changed (last reporting: 2024)	<input type="checkbox"/>	unchanged	<input type="checkbox"/>	non applicable
<input type="checkbox"/>	changed												
<input checked="" type="checkbox"/>	unchanged (last reporting: 2003)												
<input type="checkbox"/>	non applicable												
<input checked="" type="checkbox"/>	changed (last reporting: 2024)												
<input type="checkbox"/>	unchanged												
<input type="checkbox"/>	non applicable												
<p>Form C: Location of mined areas:</p> <table border="1"> <tr><td><input checked="" type="checkbox"/></td><td>changed (last reporting: 2024)</td></tr> <tr><td><input type="checkbox"/></td><td>unchanged</td></tr> <tr><td><input type="checkbox"/></td><td>non applicable</td></tr> </table>	<input checked="" type="checkbox"/>	changed (last reporting: 2024)	<input type="checkbox"/>	unchanged	<input type="checkbox"/>	non applicable	<p>Form H: Technical characteristics:</p> <table border="1"> <tr><td><input type="checkbox"/></td><td>changed</td></tr> <tr><td><input checked="" type="checkbox"/></td><td>unchanged (last reporting: 2009)</td></tr> <tr><td><input type="checkbox"/></td><td>non applicable</td></tr> </table>	<input type="checkbox"/>	changed	<input checked="" type="checkbox"/>	unchanged (last reporting: 2009)	<input type="checkbox"/>	non applicable
<input checked="" type="checkbox"/>	changed (last reporting: 2024)												
<input type="checkbox"/>	unchanged												
<input type="checkbox"/>	non applicable												
<input type="checkbox"/>	changed												
<input checked="" type="checkbox"/>	unchanged (last reporting: 2009)												
<input type="checkbox"/>	non applicable												
<p>Form D: APMs retained or transferred:</p> <table border="1"> <tr><td><input checked="" type="checkbox"/></td><td>changed (last reporting: 2024)</td></tr> <tr><td><input type="checkbox"/></td><td>unchanged</td></tr> <tr><td><input type="checkbox"/></td><td>non applicable</td></tr> </table>	<input checked="" type="checkbox"/>	changed (last reporting: 2024)	<input type="checkbox"/>	unchanged	<input type="checkbox"/>	non applicable	<p>Form I: Warning measures:</p> <table border="1"> <tr><td><input checked="" type="checkbox"/></td><td>changed (last reporting: 2024)</td></tr> <tr><td><input type="checkbox"/></td><td>unchanged</td></tr> <tr><td><input type="checkbox"/></td><td>non applicable</td></tr> </table>	<input checked="" type="checkbox"/>	changed (last reporting: 2024)	<input type="checkbox"/>	unchanged	<input type="checkbox"/>	non applicable
<input checked="" type="checkbox"/>	changed (last reporting: 2024)												
<input type="checkbox"/>	unchanged												
<input type="checkbox"/>	non applicable												
<input checked="" type="checkbox"/>	changed (last reporting: 2024)												
<input type="checkbox"/>	unchanged												
<input type="checkbox"/>	non applicable												
<p>Form E: Status of conversion programs:</p> <table border="1"> <tr><td><input type="checkbox"/></td><td>changed</td></tr> <tr><td><input checked="" type="checkbox"/></td><td>unchanged (last reporting: 2009)</td></tr> <tr><td><input type="checkbox"/></td><td>non applicable</td></tr> </table>	<input type="checkbox"/>	changed	<input checked="" type="checkbox"/>	unchanged (last reporting: 2009)	<input type="checkbox"/>	non applicable	<p>Form J: Other Relevant Matters</p> <table border="1"> <tr><td><input checked="" type="checkbox"/></td><td>changed (last reporting: 2024)</td></tr> <tr><td><input type="checkbox"/></td><td>unchanged</td></tr> <tr><td><input type="checkbox"/></td><td>non applicable</td></tr> </table>	<input checked="" type="checkbox"/>	changed (last reporting: 2024)	<input type="checkbox"/>	unchanged	<input type="checkbox"/>	non applicable
<input type="checkbox"/>	changed												
<input checked="" type="checkbox"/>	unchanged (last reporting: 2009)												
<input type="checkbox"/>	non applicable												
<input checked="" type="checkbox"/>	changed (last reporting: 2024)												
<input type="checkbox"/>	unchanged												
<input type="checkbox"/>	non applicable												

**CONVENTION ON THE PROHIBITION OF THE USE, STOCKPILING, PRODUCTION AND TRANSFER OF
ANTI-PERSONNEL MINES AND ON THEIR DESTRUCTION**

Reporting Formats for Article 7 ¹

STATE PARTY:	THE REPUBLIC OF CROATIA
DATE OF SUBMISSION	27 March 2025
POINT OF CONTACT	MINISTRY OF THE INTERIOR CIVIL PROTECTION DIRECTORATE Mr. Damir Trut, Ph.D., Director of the Civil Protection Directorate Croatian Mine Action Centre (CROMAC) sector Mr. Nikša Bogdanić, head of Sector, E-mail: hcr@civilna-zastita.hr MINISTRY OF DEFENCE Defence Policy Directorate Department of Multilateral Affairs and International Security Arms Control Department E-mail: mario.crnkoci@morh.hr

(Organization, telephones, fax, email) (ONLY FOR THE PURPOSES OF CLARIFICATION)

¹ These reporting formats informally provided by Austria on disk are based on document APLC/MSP.1/1999/L.4 of 31 March 1999, as amended and decided upon by the First Meeting of States Parties to the Convention on the Prohibition of the Use, Stockpiling, Production and Transfer of Anti-Personnel Mines and on Their Destruction, held in Maputo from 3 to 7 May 1999. Tables of formats may be expanded as desired.

Form A National implementation measures

Article 7.1 "Each State Party shall report to the Secretary-General ... on:
 a) The national implementation measures referred to in Article 9"

Remark: In accordance with Article 9, "Each State Party shall take all appropriate legal, administrative and other measures, including the imposition of penal sanctions, to prevent and suppress any activity prohibited to a State Party under this Convention undertaken by persons or on the territory under its jurisdiction or control".

State [Party]	The Republic of Croatia	Reporting for time period from	January 1, 2024	to	December 31, 2024
------------------	--------------------------------	-----------------------------------	------------------------	----	--------------------------

Measures	Supplementary information
<p>On October 1, 2004 Croatian Parliament passed a Law on Prohibition of the Use, Stockpiling, Production and Transfer of Anti-personnel Mines and on Their Destruction.</p> <p>On October 6, 2004 Croatian President signed a DECISION on the proclamation of the Law on Prohibition of the Use, Stockpiling, Production and Transfer of Anti-personnel Mines and on Their Destruction.</p> <p>Having recognized that mine/CM/UXO contamination is a problem of domestic security, economic development and environmental pollution, the current Croatian Government decided to strengthen the existing system of mine action by creating its own Office for Mine Action as a focal point in 2012. Office for Mine Action was established as a governmental body in charge of expert, analytical, counseling, and coordinative and other activities regarding the mine action in the Republic of Croatia. As such, the Office also monitors the work, activities and operations of the Croatian Mine Action Center.</p>	<p><i>Law on Prohibition of the Use, Stockpiling, Production and Transfer of Anti-personnel Mines and on Their Destruction ("OG", 141/04)</i></p> <p><i>Decree on the Office for Mine Action ("OG", 21/12)</i></p>

<p>Together with the participation in intergovernmental cooperation in the field of mine action, the Office also cooperates with different authorities in implementation of obligations under international treaties and conventions on prohibitions or restrictions on the use of certain types of conventional weapons that have unacceptable humanitarian impact, such as landmines, cluster munitions and other.</p>	
<p>The Act on Mine Action has been declared on 21 October 2015 and incorporates: Governing the wider scope of activities (ERW victims assistance, information and education about the dangers of mines, UXO and their parts, socio-economic integration of the demined areas), introduction of a new procedure – Supplementary general survey, enabled exclusion of SHAs which have undergone technical survey, SOPs have been removed, CROMAC no longer performs the assessment activities of authorized legal entities for conducting demining operations and other changes in QA/QC procedures, accreditation of legal entities and misdemeanor law regulations.</p>	<p><i>The Act on Mine Action has been enacted on 21 October 2015</i></p>
<p>In 2016, pursuant to the new Law on Mine Action, which entered into force Oct. 21, 2015, on 21 May 2016, “Regulations on how demining, quality control, non-technical and technical surveys and marking of suspected hazardous areas” have entered into force, and on 29 June 2016, “Regulations on personal supervisory booklet and ID card of mine action employees and record forms” have entered into force.</p>	

<p>As of August 2018, the Government of the Republic of Croatia had issued a Conclusion to integrate some 54 government agencies, including CROMAC and GOMA, within existing State administration bodies. This meant CROMAC and GOMA ceased to exist as a legal entity/Government Office from 1 January 2019 and were integrated into the Ministry of the Interior.</p> <p>The intentions of this formal Conclusion were formalized through the Act on Amendments to the Act on Mine Action (OG No. 118/2018) and Act on amendment to the Act on the Government (OG No. 116/2018), enacted in December 2018, entered into force on 1 January 2019 where CROMAC became an operational sector within the Civil Protection Directorate – under the Ministry of the Interior.</p>	<p><i>Act on Amendments to the Act on Mine Action (OG No. 118/2018), Act on amendment to the Act on the Government (OG No. 116/2018) entered into force on 1 January 2019</i></p>
<p>In July 2021 a new Law on Civilian Victims of the Homeland War was officially adopted by the Croatian Parliament. The new Law enables the application for the status of a war-disabled civilian, based on a disability caused by a disease correlating with the Homeland War, due among other things to disabilities caused by explosions of EO left over after the end of war operations.</p>	<p><i>Act on Civilian Victims of the Homeland War (OG No. 84/21)</i> https://www.zakon.hr/z/2851/Zakon-o-civilnim-stradalnicima-iz-Domovinskog-rata</p>
<p>In February 2023, the Croatian Parliament had officially adopted the National Mine Action Programme until 2026 as the main strategic document that clearly presents the goals and guidelines of the Mine Action in the period until 2026.</p>	<p>National Mine Action Programme until 2026 (OG 21/2023) https://narodne-novine.nn.hr/clanci/sluzbeni/2023_02_21_352.html</p>
<p>On May 26, 2023, the Croatian National Parliament had passed an amendment of the Act on Mine Action (OG 59/2003) which changes some of the regulations of the original law with a goal of increased effectiveness in land release operations.</p>	<p><i>Act on Amendments to the Act on Mine Action (OG 59/2003)</i> https://narodne-novine.nn.hr/clanci/sluzbeni/2023_06_59_999.html</p>

<p>On 18 September 2024, a new Regulation on the method of performing clearance operations, quality control, non-technical and technical survey and marking of mine suspected areas has been established by the Ministry of the Interior establishing changes and improvements especially in the terms of Open Burning and Open Detonation (OBOD) stockpile destruction clearance operations.</p>	<p>Regulation on the method of performing clearance operations, quality control, non-technical and technical survey and marking of mine suspected areas (OG 108/2024)</p> <p><i>https://narodne-novine.nn.hr/clanci/sluzbeni/2024_09_108_1855.html</i></p>
--	---

Form B Stockpiled anti-personnel mines

Article 7. 1 "Each State Party shall report to the Secretary-General ... on:
 b) The total of all stockpiled anti-personnel mines owned or possessed by it, or under its jurisdiction or control, to include a breakdown of the type, quantity and, if possible, lot numbers of each type of anti-personnel mine stockpiled."

State [Party]	The Republic of Croatia	Reporting for time period from	January 1, 2024	to	December 31, 2024
------------------	--------------------------------	-----------------------------------	------------------------	----	--------------------------

Type	Quantity	Lot # (if possible)	Supplementary information
-	-	-	-
-	-	-	-
TOTAL	-		

The Republic of Croatia destroyed its entire stockpile of anti-personnel landmines according to Article 4 of the Convention (with the exception of a small quantity retained under Article 3 of the Convention). The last amount of stockpiled anti-personnel landmines was destroyed at the Military Exercise Area "Crvena zemlja" near Knin on October 23, 2002 and was observed by a number of international observers. More detailed explanation is contained in Form "F".

Form C Location of mined areas

Article 7.1 "Each State Party shall report to the Secretary-General ... on:
c) To the extent possible, the location of all mined areas that contain, or are suspected to contain, anti-personnel mines under its jurisdiction or control, to include as much details as possible regarding the type and quantity of each type of anti-personnel mine in each mined area and when they were emplaced."

State [Party]	The Republic of Croatia	Reporting for time Period from	January 1, 2024	to	December 31, 2024
------------------	--------------------------------	-----------------------------------	------------------------	----	--------------------------

1. Achievements of the Mine action in 2024

- Land released: **43.20 km²**
 - By clearance: **34.7 km²** (55 demining projects)
 - By survey: **8,5 km²**
 - ERW found and destroyed by Mine Action authorities during clearance activities (Civil Protection Directorate; CROMAC sector, along with clearance projects in cooperation with MoD):
1395 AP mines, 22 AT mines, 1007 UXOs

In addition, certain amount of Croatian military facilities including, training areas and radar stations are still partially contaminated by ERW and under the direct responsibility of the Ministry of Defense, where the MoD Pioneer Company of the Engineering regiment is responsible for clearance of all military facilities. During 2024, an area of 7.770.168 m² under the authority of the MoD (military areas) was cleared which resulted with 295 AP mines and 18 AT mines found and destroyed along with 643 UXOs eliminated as well, which was completed in cooperation with CPD/MoI support. In addition to clearance efforts, additionally 750.000 square metres were reduced by technical survey. Altogether, during 2024, 8.520.168 m² of HA were released concerning the MoD responsibility.

As of 1 August 2020 the Republic of Croatia is declared free of all known CMR contaminated areas.

Areas returned to the community for civilian use:

The size of areas returned to the community for civilian use during 2024		43.198.951 m²
Mine clearance was conducted by:		
- Commercial demining companies		34.735.480 m²
- Survey reduction conducted by CROMAC (NTS, TS, sNTS)		8.463.471 m²
TOTAL:		43.198.951 m²

As of December 31, 2024, the areas that were included into HA by the Civil Protection Directorate, sector of CROMAC non-technical survey activities reached 402.772 m² (0.4 km²).

During clearance operations, within the reporting time period, the following devices were found and destroyed:

Anti-personnel mines		Anti-vehicle mines		Unexploded lethal ordnance		TOTAL
Civil Protection Directorate / CROMAC	Ministry of Defense (MoD)	Civil Protection Directorate / CROMAC	MoD	Civil Protection Directorate / CROMAC	MoD	Mol/CPD/CROMAC and MoD
1102	295	4	18	377	643	1.419 mines / 1.020 UXOs

The Annual Mine Action Plan (MoI) was realized using the following funding sources - State Budget funds, EU funds and Swiss-Croatian Cooperation Programme contribution. It is important to mention that, like in the previous reporting year, in 2024, funds acquired for the demining operations from the EU contribution were significant. In 2024 the state budget had the biggest financing share with 68,3 % of the realized funds while EU funds contributed with 31.5% along with Swiss-Croatian Cooperation Programme which amounted to further 0,2% of annual mine action designated funds. Parallel with the implementation of the non-technical and technical survey activities and clearance operations, the control of marking system and, if necessary, additional marking of hazardous areas was conducted in order to create a clear boundary between safe and hazardous areas. The locations of mine danger signs are one of the basic elements of the Mine Information System (MIS) that is available to public via online platform and shown on the maps given to the local authorities, police administration units and individuals that have requested maps on the HA situation. On December 31, 2024 the total hazardous area was marked with **2.610 mine warning signs**.

In addition, the Police departments have, during the course of 2024, as a part of their regular activities, Counter explosive unit (EOD) activities and annual public campaign “Less arms, less tragedies” (where the citizens are being educated as a part of EORE activities and in the same time encouraged to turn in their ERW and SALW leftovers from the Homeland War without legal penalty) collected and destroyed 138 AP and 21 AV landmines with different 3.628 pieces of UXO's. This includes Air bombs, Naval bombs, hand grenades, cluster bomblets, artillery shells (20 mm and larger), mortar shells in addition to other ERW such as different types of explosives (359 kg) and SALW ammunition (up to 14.5 mm – 411.847 pieces). The Police department will continue to implement these programs and activities in the future. The weapons and ordinances collected by the Police department were transported and destroyed at Croatia's military facilities.

2. Areas suspected to contain mines

Location	Type	Quantity	Date of emplacement	Supplementary information
THE REPUBLIC OF CROATIA Total hazardous area at the end of 2024 was 49,3* km² out of which: 43,1 km² of confirmed hazardous areas (CHAs) 6,2 km² of suspected hazardous areas (SHAs)	Anti-personnel mines	5.624		Estimate according to number of minefield records in CROMAC database and annual demining report
	Anti-vehicle mines	739		Estimate according to number of minefield records in CROMAC database and annual demining report

*Excluding the MoD areas with the additional 10,1 km² of HA recorded

Hazardous areas in the Republic of Croatia on December 31, 2024 remained on 16 Municipalities/ 3 Counties and amounted to **49.3 km²** (43.1km² CHA, 6.2 km² SHA), excluding the MoD areas of an additional approximately 10,1 km² of HA. Approximate number of AP/AT mines emplaced (Estimate according to fully documented minefield records in CPD/CROMAC sector database and Annual demining report) on Dec 31, 2024 reaches **6.363** mines (**5.624** AP mines and **739** AT mines), excluding the areas under the MoD jurisdiction. It is important to highlight that during 2024 the Republic of Croatia released completely **one more contaminated County**, when Karlovačka County was declared free of landmine contamination.

3. Remaining challenges

Remaining challenges displayed by County and Municipality level for the SHA/CHA

COUNTY	Municipalities/Towns known or suspected to contain anti-personnel mines	Amount of area known to contain anti-personnel mines (sq. meters)	Amount of area suspected to contain anti-personnel mines (sq. meters)	Total amount of area known or suspected to contain anti-personnel mines (sq. meters)
Ličko-senjska				
	Donji Lapac	5.214.924	2.673.974	7.888.898
	GOSPIĆ	14.763.517	886,868	15.650.385
	Lovinac	8,607	0	8,607
	OTOČAC	5.405.154	1.260.585	6.665.739
	Perušić	111	0	111
	Plitvička Jezera	1.369.181	0	1.369.181
	Udbina	338,509	678,716	1.017.225
	Vrhovine	10.411.396	0	10.411.396
Splitsko-dalmatinska				
	Hrvace	158.015	0	158.015
	VRLIKA	498.415	0	498.415
Sisačko-moslavačka				
	Dvor	1.279.623	531,194	1.810.817
	GLINA	541,326	15,639	556,965
	Gvozd	35,762	0	35,762
	Lipovljani	14,477	0	14,477
	Sunja	922,371	154,343	1.076.714
	Topusko	38,506	0	38,506
TOTAL	16	43.133.281	6.201.721	49.335.002

Mine Action in the Republic of Croatia has been defined by well-established priorities and sustainable development throughout the three major components: Economic growth, Environmental stewardship and Social inclusion. After the Homeland War, Republic of Croatia had prioritized the clearance of the areas that are crucial for the safety and economic growth / development of the war affected Counties, establishing preconditions for any economic activity whatsoever. After this had been finalized, priorities have turned towards the agricultural production and environmental protection. If we look at the Hazardous area land structure at the end of 2023, it can be

seen that **1.4%** of the HA were categorized as agricultural areas, **0.1%** various areas while remaining **98.5%** as forest areas. This means prioritization has changed towards the remaining challenges, so mine action activities and clearance projects have been incorporated in the last decade into various larger and sustainable society efforts. Example of these actions are especially highlighted within the clearance projects that are financed from the EU Cross border cooperation or Cohesion fund, targeting nature protected parks or Nature 2000 areas. Such projects, such as “Naturavita”, “Fearless Velebit” and “Karlovac Karst” have been and are performed within the highest possible EU and National nature protection regulations, e.g. defining the strict time frames when the clearance activities and certain methods are allowed to be performed, so the various species and habitats are not to be aggravated in any means whatsoever. Sustainable development and environmental stewardship are one of the core purposes of these projects and the remaining four year challenge focuses on the protection of forests, incorporating preservation, rehabilitation and development in the ecological and economic sense as well. This was continued in the sense of implementing two additional EU funded projects “Croatian Safe Steps” and “Croatian Safe Steps II” which are to be finalized until 2025-2026 timeframe.

4. Military facilities containing mines

Location	Type	Quantity	Date of emplacement	Supplementary information
Barracks (Total: 0 barrack)	APM	0	1991-1995	No contaminated Barracks.
	AVM	0	1991-1995	
Training Sites (Total: 2 training sites)	APM	319	1991-1995	Training sites are contaminated partially. (approx. 10,1 km ² of SHA)
	AVM	0	1991-1995	
Storage Sites (Total: 0 storage sites)	APM	0	1991-1995	There are no contaminated storage sites.
	AVM	0	1991-1995	
Radar station	APM	-	WW II,1991-1995	

(Total: 1 radar station)	AVM	-		Remaining 1 site with 280.000 m ² of SHA presumably contaminated with WWII ERW
Shooting range	APM	-	1991-1995	
(Total: 0 shooting range)	AVM	-		
Other object	APM	-	1991-1995	
(Total: 0 other object)	AVM	-		
T O T A L (Information is related to the mined area and HA in the size of 10.38 km ²)	APMs (anti-personnel mines)	319	1991-1995	
	AVMs (anti-vehicle mines)	0	1991-1995	
In 2024 Croatian Army units cleared an area of military facilities			T O T A L	285.789 m²

During 2024 an area of 8.520.168 m² under the authority of the MoD (military areas) was released - 285.789 m² was cleared and 750.000 m² reduced by the MoD Pioneer Company of the Engineering regiment, while additional area of 7.770.168 m² was cleared 4in cooperation with the Ministry if the Interior – Civil Protection Directorate – CROMAC trough public tender.

Thanks to the Civil Protection Directorate - CROMAC **Mine-Information System portal** <https://misportal.hcr.hr/HCRweb/faces/intro/introduction.jspx> every Internet user can through this web application have an insight into suspected hazardous areas and positions of mine danger sings. This kind of SHA display through web application is unique in the world. Users are also informed through detailed maps provided with locations of mine danger signs and mobile application MINEfields.info. CROMAC MIS portal is available to all Internet users within a public access and suspected hazardous areas can be browsed by counties, municipalities, towns or settlements.

Form D APMs retained or transferred

Article 7.1 "Each State Party shall report to the Secretary-General ... on:

d) The types, quantities and, if possible, lot numbers of all anti-personnel mines retained or transferred for the development of and training in mine detection, mine clearance or mine destruction techniques, or transferred for the purpose of destruction, as well as the institutions authorized by a State Party to retain or transfer anti-personnel mines, in accordance with Article 3"

State [Party]	The Republic of Croatia	Reporting for time period from	January 1, 2024	to	December 31, 2024
---------------	--------------------------------	--------------------------------	------------------------	----	--------------------------

1. Retained for development of and training in (Article 3, para.1)

Institution authorized by State Party	Type	Quantity	Lot # (if possible)	Supplementary information
Mines are stored at the Croatian Armed Forces storage site "Borik" Velika Buna, and are used or going to be used by the Croatian Mine Action Centre-Center for testing, development and training	PMA-1	431	-	No serial mark on the mine or on the package
	PMA-2	487	SRB 6741, 6743, 6745, 6746, 6748,6749, 6750	
	PMA-3	75	SRB 8702	
	PMR-2A	769	-	No serial mark on the mine or on the package
	PMR3	70	PIG-8900	

Institution authorized by State Party	Type	Quantity	Lot # (if possible)	Supplementary information
--	-------------	-----------------	----------------------------	----------------------------------

	PROM-1	1.732	KV 00/64, 01/64, 05/65, 06/65, 07/65, 08/65, 11/65, 12/65, 03/65, 04/65, 02/66, 01/68, 02/68, 03/70, 03/70 03/76	
TOTAL	-----	3.564		

Based on the Agreement on the transfer of tasks, Article 2, signed between Croatian Mine Action Center and Center for Testing, Development and Training (HCR-CTRO Ltd.) on October 30, 2003 HCR-CTRO Ltd. took over the activities and projects focused on performing administrative and technical tasks related to testing of machines, dogs and detectors, as well as scientific and research activities.

Total number of anti-personnel mines used in 2024 in accordance with Article 3 is the following:

Institution authorized by State Party	Type	Quantity	Used in Military training for deminers	2024
<ul style="list-style-type: none"> HCR-CTRO Ltd. used AP mines for testing in 2024 	PMA-1	30	0	
	PMA-2	15	0	
	PMA-3	15	0	
	PMR-2A	6	0	
	PROM-1	6	0	
TOTAL:		72		

2. Estimate of the use of mines in year 2025

In year 2025, the amount of anti-personnel landmines that will be used (and consequently destroyed) will be based on the needs for testing of demining machines. CAF will use only “inert” APMs for training purposes.

Form E Status of programs for conversion or de-commissioning of APM production facilities

Article 7.1 "Each State Party shall report to the Secretary-General ... on:
 e) The status of programs for the conversion or de-commissioning of anti-personnel mine production facilities."

State [Party]	The Republic of Croatia	reporting for time period from	January 1, 2024	to	December 31, 2024
------------------	--------------------------------	-----------------------------------	------------------------	----	--------------------------

Indicates if to "convert" or "decommission"	Status (indicates if "in process" or "completed")	Supplementary information
-	-	-
-	-	-

The Republic of Croatia did not produce any anti-personnel landmines.

Form F Status of programs for the destruction of APMs

Article 7.1 "Each State Party shall report to the Secretary-General ... on:
 f) The status of programs for the destruction of anti-personnel mines in accordance with Articles 4 and 5, including details of the methods which will be used in destruction, the location of all destruction sites and the applicable safety and environmental standards to be observed."

State [Party]	The Republic of Croatia	Reporting for time period from	January 1, 2024	to	December 31, 2024
---------------	--------------------------------	--------------------------------	------------------------	----	--------------------------

1. Status of programs for destruction of stockpiled APMs (Article 4)

The Republic of Croatia met its commitments by destruction of all its stockpiled anti-personnel landmines, except those retained under Article 3.	
Description of the status of programs including:	Details of:
Location of destruction sites: Military training area "Oštarski dolovi" near Slunj and "Crvena zemlja" near Knin.	
<ul style="list-style-type: none"> - Mines destroyed by: - Explosion (PMA-3, PMA-2, PROM-1) - Disassembling (PMA-1, PMR-2A) 	Methods
National safety standards are applied according to Ministry of Defense regulations, taking into account international standards for humanitarian demining.	Applicable safety standards
Mines were destroyed at military training areas away from inhabited areas (minimal distance 5 - 8 kilometers).	Applicable environmental standards

The destruction of stockpiled anti-personnel landmines was conducted in three phases and the following quantities of anti-personnel landmines were destroyed:

No	Type	Phase I (Sep 4 – Oct 26, 2001, and earlier)	Phase II (April 8 – July 5, 2002)	Phase III (Sep 9 – Oct 24, 2002)	TOTAL
1.	AP landmine PMA-1	7.875	3.831	2.574	14.280
2.	AP landmine PMA-2	9.979	21.032	13.865	44.876
3.	AP landmine PMA-3	19.372	23.667	16.662	59.701
4.	AP landmine PMR-2A, 2AS	21.364	32.027	20.649	74.040
7.	AP landmine PMR-3	-	4	-	4
8.	AP landmine PROM-1	2.144	3.382	576	6.102
TOTAL		60.734	83.943	54.326*	199.003

* During the Phase III, 53.908 anti-personnel landmines were initially destroyed. Additional 418 anti-personnel landmines were delivered by the Ministry of Interior after the successful completion of their "Farewell to Arms" campaign whose aim was to collect weapons and other explosive remnants of war. The total number of destroyed stockpiled anti-personnel landmines in Phase III was 54.326.

Apart from anti-personnel mines, during Phase III, the following additional quantities of fuses for anti-personnel landmines were destroyed:

No	Type	Phase I (Sep 4 – Oct 26, 2001)	Phase II (April 8 – July 5, 2002)	Phase III (Sep 9 – Oct 24, 2002)	TOTAL
1.	AP landmine fuse UPMR-2A, 2AS	2.390	13.063	23	15.476
2.	AP landmine fuse UPMR-3	1.840	11.136	280	13.256
3.	AP landmine fuse UPROM-1	1.474	10.250	146	11.870
4.	AP landmine fuse UPMAH-1	1.086	1.328	100	2.514
5.	AP landmine fuse UPMAH-2	936	830	194	1.960
6.	AP landmine fuse UPMAH-3	237	133	133	503
TOTAL		7.963	36.740	743	45.579

The process of destroying stockpiled anti-personnel landmines was observed by international monitors/observers on September 12 and 25, 2001 and on October 22/23, 2002. During the observation, the Republic of Croatia was praised for meeting its commitments pursuant to the Ottawa Convention. After an extensive overview, the increased number of stockpiled anti-personnel landmines was evidenced chronologically as follows:

First notified amount of stockpiled APMs	189.251
Collected after first MI action "Farewell to Arms"	3.531
TOTAL	192.782
Collected after second MI action "Farewell to Arms"	3.098
TOTAL	195.871
Military stocks inventory check evidenced a larger number of stockpiled APMs	9.460
TOTAL	205.331
Collected after third MI action "Farewell to Arms"	418
TOTAL	205.749
Total amount of APMs possessed by the Republic of Croatia	205.749
Total amount of destroyed APMs	199.003
Amount retained under Article 3 of the Convention²	7.000

The cost of destroying stockpiled APMs is provided (in Euros) as follows:

² 268 anti-personnel landmines were destroyed during 2003 for the purposes according to Article 3 of the Convention.

No	Purpose	Phase I (Sep 4 – Oct 26, 2001)	Phase II (April 8 – July 5, 2002)	Phase III (Sep 9 – Oct 24, 2002)	TOTAL
1.	Daily payment to technicians	3.821	5.879	3.135	12.835 €
2.	Daily payment to supervisors	1.274	980	523	2.777 €
3.	Additional payment to technicians	3.821	5.879	3.135	12.835 €
4.	Accommodation costs for technicians	4.039	6.213	4.843	15.095 €
5.	Accommodation costs for supervisors	1.346	1.036	807	3.189 €
6.	Daily payment for drivers	1.274	1.952	1.045	4.271 €
7.	Costs of machines and vehicles	15.984	24.575	13.115	53.674 €
8.	Costs for explosive ordinance for ignition	2.175	3.346	446	5.967 €
TOTAL*		33.734 €	49.860 €	27.049 €	110.643 €*

*Salaries for all personnel involved in the process are not included in the abovementioned.

The cost of destruction per anti-personnel landmine was 0.56 €.

2. Status of programs for destruction of APMs in mined areas (Article 5)

Description of the status of programs including:	Details of:
Location of destruction sites	
	Methods
	Applicable safety standards
	Applicable environmental standards

Form G APMs destroyed after entry into force

Article 7.1 "Each State Party shall report to the Secretary-General ... on:
 g) The types and quantities of all anti-personnel mines destroyed after the entry into force of this Convention for that State Party, to include a breakdown of the quantity of each type of anti-personnel mine destroyed, in accordance with Articles 4 and 5, respectively, along with, if possible, the lot numbers of each type anti-personnel mine in the case of destruction in accordance with Article 4"

State [Party]	The Republic of Croatia	Reporting for time period from	January 1, 2024	to	December 31, 2024
------------------	--------------------------------	-----------------------------------	------------------------	----	--------------------------

1. Destruction of stockpiled APMs (Article 4)

Type	Quantity	Lot # (if possible)	Supplementary information
/	/	/	/
TOTAL			

Information is provided in Form "F".

2. Destruction of APMs in mined areas (Article 5)

Type	Quantity	Supplementary information
PMA-1	30	
PMA-2	30	
PMA-3	433	
PMR-2A	420	

PMR-2AS	33	
PROM-1	189	
MRUD	5	
Other	255	
TOTAL	1.395	

***Apart from the destroyed AP mines during clearance activities under responsibility of the MoI/CPD, throughout 2024, additionally 2 AP mines have been found and destroyed as well, under the Ministry of Defence clearance activities.**

Form H Technical characteristics of each type produced/owned or possessed

Article 7.1 "Each State Party shall report to the Secretary-General ... on:

h) The technical characteristics of each type of anti-personnel mine produced, to the extent known, and those currently owned or possessed by a State Party, giving, where reasonably possible, such categories of information as may facilitate identification and clearance of anti-personnel mines; at a minimum, this information shall include the dimensions, fusing, explosive content, metallic content, color photographs and other information which may facilitate mine clearance"

State [Party]	The Republic of Croatia	Reporting for time period from	January 1, 2024	to	December 31, 2024
---------------	--------------------------------	--------------------------------	------------------------	----	--------------------------

Technical characteristics of each APM-type currently owned or possessed

Type	Dimensions	Fusing	Explosive content		Metallic content	Colour photo attached	Supplementary information to facilitate mine clearance.
			Type	Grams			

At the end of 2024, the Republic of Croatia was in possession of 3.564 anti-personnel landmines retained under Article 3 of the Convention, as described in form "D".

Name : PMA-1A

Type : Anti-personnel antimagnetic pressure mine

Description : Antimagnetic anti-personnel landmine, colored olive drab, no markings. Activated by the pressure of approx. 3 kp. Can be buried to the depth of 3-5 cms. Often an additional TNT charge (TM-200) is placed under it to increase the lethality. Causes heavy injuries to the person activating it.

Technical data

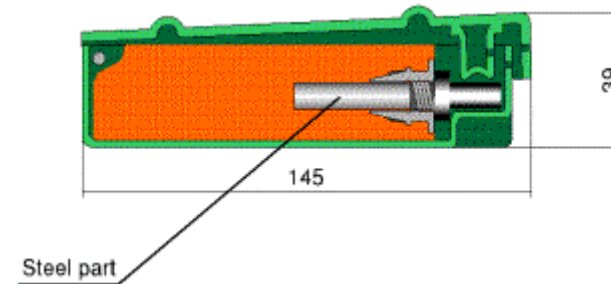

Length : 145 mm

Width : 68 mm

Height : 39 mm

Mass : 400 g

Explosive charge : 200 g TNT

Body : Plastic

Colour : Olive-drab

Fuse type : Chemical

Mode of activation: Pressure

Sensitivity : 3 – 18 kps

Detectability : Very hard to detect by the magnetic mine detector (minimal metal contents)

Mode of operation : The pressure of 3-18 kps on the lid of the mine will break the fuse containing the chemical compound sensitive to friction, which will incinerate and activate the detonator cap by spark. The detonator cap, in turn, will detonate the explosive charge of the mine. The effect of the mine is the direct blasting effect to a person stepping on it.

Name : PMA-2

Type : Anti-personnel antimagnetic pressure mine

Description : Non-metallic anti-personnel mine the size and shape of the liver paste tin, hence the popular name "liver paste." Recognizable by the characteristic star-shaped fuse. Mostly colored olive-drab, but there are white ones. Activated by approx. 5 kps pressure. Can be placed upside down to hide the fuse. Causes grave injuries to the person activating it.

Technical data

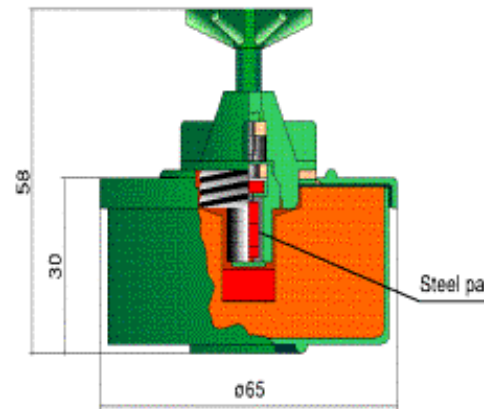

Diameter : 65 mm

Height : 58 mm (with fuse)

Mass : 135 g

Explosive charge 70 g paraffin-protected TNT

Casing : Plastic

Colour : Olive-drab

Fuse type : Chemical

Mode of activation: Pressure

Sensitivity : 5 – 15 kps

Detectability : Very difficult to detect by magnetic mine detector (minimal metal contents)

Mode of operation : Pressure of 5 and more kps to the pressure star will cause the needle to penetrate the membrane, penetrate through the incendiary compound causing the incineration by friction. Pulse of flame will be carried to the detonator cap, which in turn carries the detonation to the explosive charge. The effect of the mine is the blast of the explosive to the person stepping on the mine.

Name : PMA-3

Type: Anti-personnel antimagnetic pressure mine

Description: Antimagnetic anti-personnel mine, activated by pressure to the upper round pad in any direction. The body of the mine is cylindrical and made of plastic. It consists of the upper and lower part connected in the centre, and forming a swivel along the rim. Both parts are connected along the edge by rubber. The lower part contains the fuse well. The mine is waterproof and is therefore often placed on the riverbanks and in shallow waters, and can remain live for many years after it is placed. The explosive charge is in the upper part of the body and effects are considerably stronger than with e.g. blast of PMA-2.



Technical data

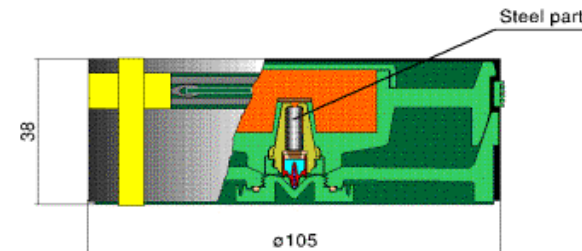

Diameter : 105 mm
Height : 38 mm
Mass : 183 g
Explosive charge 35 g TNT
Casing : Plastic / rubber
Colour : Olive / black
Fuse type : Chemical

Mode of activation: Pressure
Sensitivity : 3 - 15 kps
Detectability : Very difficult to detect by the magnetic mine detector (minimal metal contents)
Mode of operation : Pressure of 3 and more kps to the upper part of the mine one of the sides of the upper part will bring closer to the bottom part, breaking the circular carrier of the initial (incendiary) compound, causing it to incinerate. The impulse of flame is transferred to the detonator cap, which transfers the detonation to the main explosive charge of the mine. The blast effect is aimed at the person activating the mine.

Name : PMR-2A

Type : Anti-personnel fragmentation mine – tripwire activated

Description : The body of the mine is cylindrical, made of cast steel, prefragmented on the outer surface for more regular fragmentation, and smooth from the inner side, containing the explosive charge. It is placed on top of the wooden or metallic post stuck into the ground. One or more tripwires are connected to the fuse on top of the mine. The pulling force of 3 kps or more on the tripwire activates the mine. When the mine is activated, fragments are lethal within 25 m radius in any direction, and cause injuries in the radius of up to 100 m. depending on the desired effects of the mine, two types of fuses can be used. If, together with the main blast effect of the mine illumination of the field around it is desired, instead of the UPM-2a fuse, UPM-2AS fuse with illumination flare can be used.

Technical data

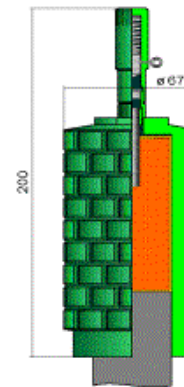

Diameter : 66 mm
Height : 140 mm (body only), 200 mm with fuse
Mass : 1.7 kps
Explosive charge : 100 g TNT
Made of : Cast steel
Colour : Olive-drab
Fuse type : Mechanical – pulling (standardized for this type of mine)
Activation mode : Pulling of tripwire (no delay)

Sensitivity : 3 kps (depending on the condition of the safety feature of the firing pin and firing pin in the fuse)
Detectability : Visual, as it is placed on the post
Lethal radius : 25 m
Danger radius : 100 m
Mode of operation : By pulling the tripwire with the force of 3 or more kps, safety feature is pulled out of the fuse body, releasing the firing pin which, driven by the spring, hits the initiating part and activates it. The detonation pulse is transferred to the detonator cap, which detonates, into the main explosive charge of the mine. The blast breaks the body of the mine into small pieces (fragments) directed radially from the place of activation of the mine and which achieve lethal or maiming effect.

Name : PMR-3

Type : Anti-personnel fragmentation mine

Description : The body of the mine is cylindrical, made of wrought iron and prefragmented – cut for easier disintegration into small pieces, while the inner side is smooth. On the side of the body there are two carriers for attachment of the mine to the appropriate stake (provided with the mine). To keep the tripwire as close to the ground as possible this mine is often placed upside down. The central part of the fuse can be rotated and five tripwires can be attached to it. This mine is colored olive-drab and often the name is stenciled in black on the body. It is activated by the pressure of 9 kps on the top of the mine or pull of 3 kps to the tripwire. Fragments are lethal in the radius of 50 m, and dangerous in the radius of 100 m.

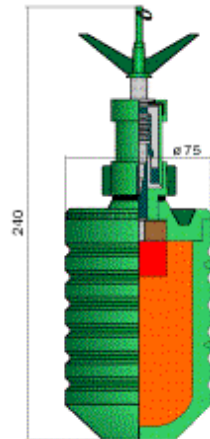

Technical data

Diameter : 75 mm
Height : 240 mm
Mass : 1.7 kgs
Explosive charge : 410 g TNT
Material : Wrought steel
Colour : Olive-drab

Fuse type : Radial pull – pressure type
Sensitivity : Pressure 9 - 15 kps, pull 3 - 8 kps
Detectability : Visual, the mine is placed on the stake
Lethal radius : 25 m
Danger radius : 50 m
Mode of operation : By pulling at the tripwire with the force of 3 kps and more the carrier of the firing pin releases the firing pin which, influenced by the spring, strikes the initializing part of the detonator and activates it. The spark is carried to the detonator cap, which activates the main explosive charge. The blast breaks the body into small fragments directed radially from the spot of detonation, and achieving lethal or maiming effect.

Name : PROM-1

Type : Anti-personnel bounding fragmentation mine

Description : Olive-drab mine with smooth body placed underneath the surface to the neck of the fuse. The body is prefragmented from the inner side. It is recognizable by the safety device with four ends protruding from the ground. The ring on the top of the central part facilitates the attachment of five tripwires simultaneously. When activated, the mine bounces from its layer in the ground to the height of 0.7 – 0.8 meters and detonates. Explosive charge is most commonly 425 grams of cast TNT that is sufficient for the lethal radius of 50 meters, and danger radius of 100 meters. It is often found placed as a booby-trap on paths, forest roads, entrances in industrial plants and elsewhere.

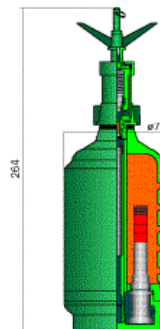

Technical data

Diameter : 75 mm
Height : 264 mm (body and fuse)
Mass : 3 kps
Explosive charge : 425 g cast TNT
Material : Wrought steel

Colour : Olive-drab
Fuse type : Pressure - pull (radial)
Sensitivity : Pressure 9 kps, tripwire 3 kps
Detectability : Visual identification of the tripwire or protruding assembly, considerable metallic mass
Lethal radius : 25 m (360 degrees)
Danger radius : 50 m (360 degrees)
Mode of operation: Pulling of the tripwire or pressure to the crown of the fuse releases the firing pin, which strikes the initiating cap. The initiating cap lights the delay, which carries the pulse to the powder charge, which ejects the mine from the ground. After the mine had been ejected from the ground, due to the pull of the wire on the internal fuse, the fuse activates and the detonation is carried to the main explosive charge which blasts the body and scatters the fragments radially from the mine. The effect is expressed through the explosive blast and strike of the fragments.

Form I Measures to provide warning to the population

Article 7.1 "Each State Party shall report to the Secretary-General ... on:
i) The measures taken to provide an immediate and effective warning to the population in relation to all areas identified under paragraph 2 of Article 5."

Remark: In accordance with Article 5, para.2: "Each State Party shall make every effort to identify all areas under its jurisdiction or control in which anti-personnel mines are known or suspected to be emplaced and shall ensure as soon as possible that all anti-personnel mines in mined areas under its jurisdiction or control are perimeter-marked, monitored and protected by fencing or other means, to ensure the effective exclusion of civilians, until all anti-personnel mines contained therein have been destroyed. The marking shall at least be to the standards set out in the Protocol on Prohibitions or Restrictions on the Use of Mines, Booby-Traps and Other Devices, as amended on 3 May 1996, annexed to the Convention on Prohibitions or Restrictions on the Use of Certain Conventional Weapons Which May Be Deemed to Be Excessively Injurious or to Have Indiscriminate Effects".

State [Party]	The Republic of Croatia	Reporting for time period from	January 1, 2024	to	December 31, 2024
------------------	--------------------------------	-----------------------------------	------------------------	----	--------------------------

The activities by Croatia to disseminate information about the Convention and the Protocols to the civilian population take place at several levels. The texts of the Convention and all Protocols to the Convention ratified by the Republic of Croatia were published in Official Gazette of the Republic of Croatia (International Agreements Section) and are hence available to public as a bulletin in printed version and on website: www.nn.hr.

Dissemination of information about the Ottawa Convention to civilian population also includes Explosive Ordnances Risk Education (EORE) activities. Croatian ministries, government and state administrative offices as well as professional groups working with and for adults and children in Croatia, including NGOs and international organizations, pass specific training according to their role in the national implementation of the Convention and Protocols. Croatian Red Cross with its branches (in local communities), Civil Protection Directorate of the MoI and the Association of Civil Victims of Homeland War are active in events and lectures where EORE messages are given. The lectures always bear in mind that EORE is effective in terms of reducing the number of mine casualties. Interesting presentations (lectures) on mine/UXO risk education were organized for children, adults, and especially for target groups (hunters, fishermen, farmers, public companies employees etc.). The purpose of these educations was to learn and spread knowledge on danger of mines and other Explosive Remnants of War (ERW).

Promotion to the public and the media is an especially important way to directly spread safety messages on the dangers of ERW, which seeks to inform as many citizens at local and national level. Creating and distributing posters, flyers, brochures, etc. and publishing news stories in print and electronic media (radio and TV) includes a significantly larger number of citizens, and further points to the still present danger of landmines in Croatia.

Different EORE activities, systematic marking of the Hazardous Areas (HA), possibility of getting an insight into mine situation throughout submission of HA maps as well as using Civil Protection Directorate / CROMAC web portal had a highly positive effect on the prevention of mine incidents or accidents, but also required additional activities of informing the public and media of different mine action aspects. In addition to traditional EORE methods CROMAC, with its partners, had developed the Minefields.info application for Android and iOS smart phones, to further tackle and increase the availability of mine warning information towards the general public. The main purpose of mentioned app is to warn the user of a life-threatening danger caused by entering or approaching the vicinity of HA. It works on a basis of distance and GPS tracking so if user gets closer to a hazardous area the application will alert him immediately. The application also has "Call for Help" option and to report and take a photo of unknown potential ERW, along with a database of known ERW in the corresponding country, which further provides EORE available through smartphones.

1. Explosive Ordnance Risk Education (EORE) in 2024

In 2024, all EORE activities were coordinated within the Civil Protection Directorate (CPD) of the Ministry of Interior, and directly provided or with the support of the National educational centre of Civil protection - which is an organizational sector within the CPD. In 2024, a total of 121 EORE were held in 8 Counties. The EORE activities covered a total of about 11,252 people, mostly elementary school age, as well as the target population of the local inhabitants of municipalities and cities within the hazardous areas. The trainings were conducted by the officers of the Civil Protection Directorate in cooperation with officials of the authorized police precincts. The number of activities related to the education about dangers of mines and UXO were done in cooperation with the Ministry of the Interior relevant police departments through the "Less arms, less tragedy" campaign. The cooperation was also achieved with the city and municipal governments and other non-governmental organizations and associations.

Central ceremony for the April 4th, International day of Mine Awareness and Assistance in Mine Action was held in the usual capacity gathering major public media with organized press conference by the Ministry of the Interior, along with the established promotion and awareness messages sent to various offline and online media channels highlighting the importance of mine risk and awareness. The Ministry of the Interior marked April 4th – presenting the created promotional film concerning the Mine Action in the Republic of Croatia - from Challenges to Opportunities which showed the path of demining process in the Republic of Croatia from 1996 to the 2024, after which the Deputy Prime Minister and Minister of the Interior and the Minister of Regional Development and European Union Funds addressed the attendees.

All important actions and activities of Mine Action in the Republic of Croatia in 2024 were presented on web pages/social media channels of the Civil Protection Directorate of the Ministry of the Interior of the Republic of Croatia.

2. Mine accidents / incidents in 2024

In 2024 there were **no accounted mine accidents or incidents whatsoever.**

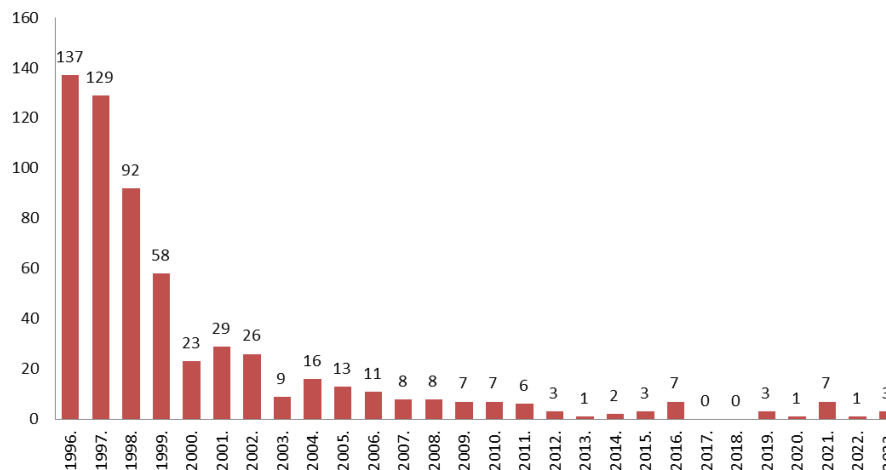

Overview of Mine victims in the 1996-2024 periods

From 1996 (end of the Homeland war) till the end of 2022, the Republic of Croatia had accounted mine accidents or incidents where **610** people were harmed, out of which **207** with a fatal outcome. These unfortunate numbers also include **134** injured deminers, out of which **40** were fatalities.

Form J: Other relevant matters

Remark: State Parties may use this form to report voluntarily on other relevant matters, including matters pertaining to compliance and implementation not covered by the formal reporting requirements contained in Article 7. States Parties are encouraged to use this form to report on activities undertaken with respect to Article 6, and in particular to report on assistance provided for the care and rehabilitation, and social and economic reintegration, of mine victim.

State [Party]	The Republic of Croatia	Reporting for time period from	January 1, 2024	to	December 31, 2024
------------------	--------------------------------	-----------------------------------	------------------------	----	--------------------------

Highlights of Mine Victims’ Assistance in 2024

The Republic of Croatia has developed public health care structure that includes clinics, clinical centers, specialized polyclinics, hospitals and rehabilitation centers. All persons being involved in the incidents are entitled to health protection and acquisition of orthopedic aids to the amount covered by the Croatian Health Insurance Institute. These rights are regulated by a number of laws, rules and regulations. Relevant state administration authorities are involved in solving the problems of mine victims relating to medical rehabilitation, socio-economic empowerment and other needs.

The most important elements were presented during 2024 at the Regional Conference on Advancing Victim Assistance Implementation and Cooperation held in Ljubljana, Slovenia presenting the activities of the mine action system of the Republic of Croatia with an emphasis on highlighting all of the activities carried out within the project "Demining and Socio-Economic Integration" financed by the Swiss Croatian Cooperation Programme.

The Swiss-Croatian Cooperation Programme contribution and a specific project named “**Demining and Socio-Economic Integration**” has been carried out in the 2017-2024 period. After significant demining results, one of the activities that were finalized in 2021, after a full-scale field survey, was the establishment of a comprehensive EO database, gathering, among other elements, the information about different needs, vulnerabilities and perspectives of women, girls, boys and men from diverse populations and all ages. We can conclude that this field survey was completed with a very good response rate of 82.6% of the available households (data was gathered from 423 EO victims and 473 EO closest family members.) The collected data concerned the social status, psycho-physical health, education, etc., and became an integral part of the comprehensive EO victim database, together with the analysis base value that will serve in future project activities / VA activities. Further project activities continued in 2022 with the development and implementation of specific VA programs for psychosocial empowerment including counseling and educational

activities, and an initiative to improve the social status of EO victims and their families featuring specific workshops and trainings that continued in 2023. In addition, a thematic brochure has been published (https://civilna-zastita.gov.hr/UserDocsImages/CIVILNA%20ZA%C5%A0TITA/PDF_ZA%20WEB/20220105_MUP_brosura_small.pdf), which contains all the rights and opportunities available to EO victims in the Republic of Croatia and the manner to exercise them.

During 2022 as a part of Psychosocial workshops, 9 assistance workshops were held gathering 39 EO victim participants, while within Training, Counseling and Employability increase workshops, 4 workshops and 12 specific trainings were held with a total of 36 EO victim participants. During 2023 an activity of small scale investment opportunities to EO victims aimed in increasing their economic welfare and employment capacities has been carried. Financial resources were allocated (Public Call) towards the Mine Victims in the amount of CHF 200,000.00, which financed the start of new and expansion of existing entrepreneurs for the 15 mine victims and members of their immediate families (indirect victims). In 2024, an additional demining project was completed from the leftover funds resulting with 81.386 m² of released land along with 30 AP mines and 1 UXO found and destroyed. This was the last activity of this important project, so all activities have been finalized in mid-2024.

The Republic of Croatia has highly developed legal framework relating to the persons with disabilities in realizing their legitimate rights and status. The status and various forms of rights are being realized through over 200 different laws and by-laws. There are 4 basic forms of mine victim assistance in which ministries, institutions, non-governmental sector, a number of organizations and individual initiatives take part in, such as medical care, physical rehabilitation, psychological help and social reintegration and professional and economic rehabilitation. Additionally, we have to emphasize the strong determination of the Croatian Government and efforts to improve the inclusiveness and support for the EO victims continuously, even 20 years after the Homeland War ended. This is reflected through the enhancement of the legal framework when in July 2021 a new Law on Civilian Victims of the Homeland War was officially adopted by the Croatian Parliament. The new Law enables the application for the status of a war-disabled civilian, based on a disability caused by a disease correlating with the Homeland War, due among other things to disabilities caused by explosions of EO left over after the end of war operations. This means the Law will provide the same legal security to civilian victims as is already provided to the Croatian War Veterans, and among others, to EO survivors and families of individuals killed by EO, all with a goal to greatly improve socioeconomic status of the victims.

Finally, the victim assistance is currently and will be considered as a combined, cross-ministry and institutional effort which is to be coordinated by the Coordination body. Coordination body would be composed of representatives of ministries competent for home affairs, health and war veterans, Croatian Pension Insurance Institute, Croatian Institute of Public Health and other bodies and non-government organizations whose scope of competence includes the issue of victims of explosive remnants of war and CMR as well and who already perform assistance to ERW victims' altogether. Coordination body is still in the process of constituting and until the finalization of this process the **relevant Sector at the Civil Protection Directorate of the Ministry of the Interior** is currently national contact point regarding the victims.

Highlights of International Cooperation, Technical Assistance and Advocacy in 2024

The Ministry of the Interior, Civil Protection Directorate officials have continuously during 2024 provided thorough support and transparent information towards the international partners and organizations regarding the APMBC, CCM and CCW Conventions as well as Landmine Monitor, OSCE, Mine Action review (NPA), EU institutions Mine Action focal points and all other interested foreign Embassies and officials.

- Participation of the Croatian delegation at The Siem Reap-Angkor Summit on a Mine-Free World - the Fifth Review Conference (5RC) of the Convention
- The 20th International Symposium "Mine Action 2024" was held in April 2024, co-organized by the Ministry of Interior and the Centre for Testing, Development and Training Ltd, and under the auspices of the Croatian Parliament. The 20th International Symposium "Mine Action 2024" was an event for exchanging experiences, considering solutions to technical and management problems and gaining insight into the latest technologies in the field of humanitarian mine action, and was attended by more than 220 participants from 35 countries worldwide.
- A representative of the Civil Protection Directorate of the Ministry of Interior participated during May 2024 at the Security Cooperation Forum of the Organization for Security and Co-operation in Europe (OSCE) and presented the achievements and experiences of the Republic of Croatia in humanitarian mine action.
- During March 2024, At the meeting of the Committee on Migration, Refugees and Displaced Persons of the Parliamentary Assembly of the Council of Europe in Paris, France, the mine action system of the Republic of Croatia was presented. The presented information, along with the accompanying discussion, was subsequently integrated into the Resolution of the Parliamentary Assembly of the Council of Europe on the use of explosive weapons, as one of the significant factors influencing population displacement.
- Support of the Republic of Azerbaijan Humanitarian Mine Action in the context of providing donation of eight Mine Detection Dogs along with the additional support activities including the education of four dog handlers which visited Croatia and completed training in 2024.
- In May 2024, FindMine gGmbH carried out development and validation tests of their UAV-based ground penetrating synthetic aperture radar (GPSAR) at the CROMAC-CTRO ltd test site in Benkovac. They tested the possibility of detecting real disarmed mines, both AP and AT, and UXOs.

Supporting the Mine Action efforts of Ukraine

- During 2024, the Ministry of the Interior, in cooperation with the NGO "Croatia Helps", held several EORE education sessions for children from Ukraine who were visiting the Republic of Croatia as a war relief Programme.

- Two expert workshops on the topic "Train the Trainers - Implementation of EORE for the Civilian Population" were also held for the employees of the Ministry of the Interior of Ukraine.
- Cooperation was also established through participation of the Republic of Croatia in the Humanitarian Demining Coalition for Ukraine as well as through the participation of representative of the Ministry of the Interior in the Advisory Board of the Centre for Humanitarian Demining of Ukraine.
- At the International Conference on Humanitarian Demining of Ukraine in Lausanne, Swiss Confederation, a representative of the Ministry of Interior participated as a panellist and as Vice-Chairman of the Advisory Board of the Centre for Humanitarian Demining of Ukraine, where the institutional and systematic approach of the Republic of Croatia to new technologies and innovative solutions were presented.
- During the 27th International Meeting of Mine Action National Directors & UN Advisers in Geneva, CROMAC – Centre for Testing, Development and Training (CTRO) Ltd and Ukranian Center for Improvement of Mine Action and Environmental (CIMAES) signed a Memorandum of Understanding establishing a cooperative framework for the exchange of knowledge, sharing of experiences, and fostering innovations within the humanitarian demining sector.
- As part of the project titled "Comprehensive Support to the National Mine Action Sector of Ukraine, Component 2: Support to Strengthen Humanitarian Mine Action in Ukraine," a series of workshops were organized in Kyiv during 2024. This project is implemented by the CROMAC-CTRO Ltd in collaboration with the Civil Protection Directorate and financed within the Service for Foreign Policy Instruments – FPI of the EC with a goal of enhancing the capacity of state humanitarian mine action operators in Ukraine by providing strategic and technical guidance on the integrated management of mine action activities.

Furthermore, Civil Protection Directorate (CROMAC sector) and CROMAC- CTRO LLC* have actively, throughout 2024 offered and provided some of the following forms of assistance to the international Mine action community, stakeholders and MACs:

- Establishment of the National mine action centre,
- Legal, sub legal and normative regulations,
- Establishment of mine information system and geo-information system,
- Planning system – production of National strategies, annual and operative activity plans,
- Education of executors of humanitarian demining operations (deminers, auxiliary workers and management) and mine risk education,
- General survey, definition of suspected hazardous area and education of survey teams,
- Protective equipment and demining machines produced in the Republic of Croatia,
- Capacities and know-how of the Croatian demining companies,
- Capacities for testing demining machines, equipment and devices as well as new technologies of mine and UXO detection